

Orificio de desague "GT" s/plano nº AH 10692.
 en su última revisión.

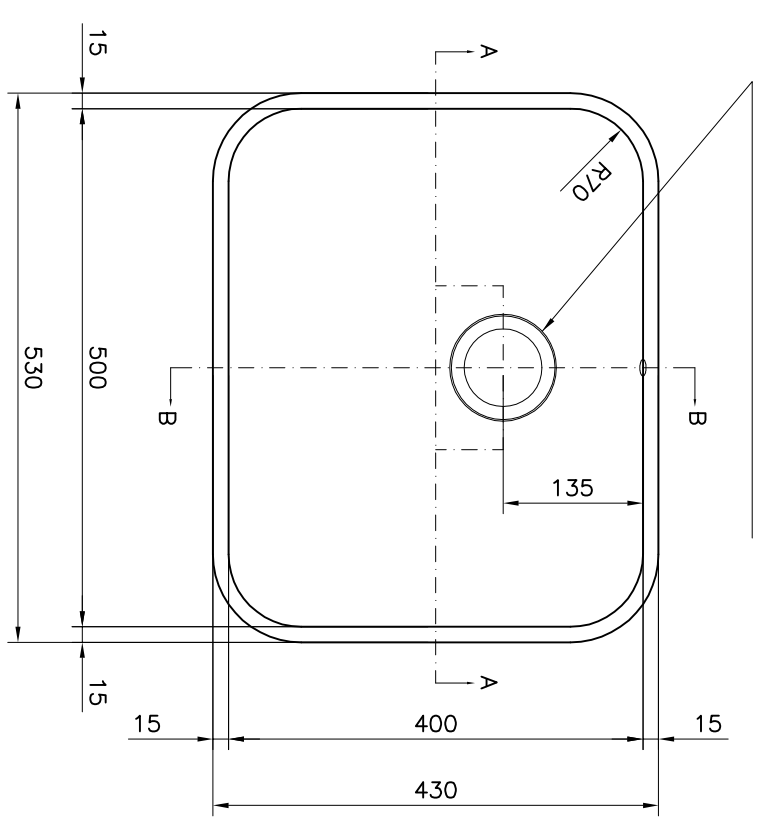

Características:
 -Insonorizado.
 -Alo de la cubeta libre de rebabas.

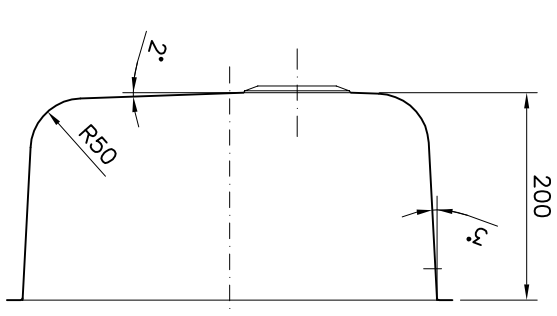

SECCIÓN B-B

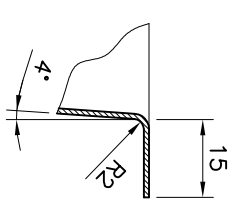

DETALLE A
 ESCALA 1:1

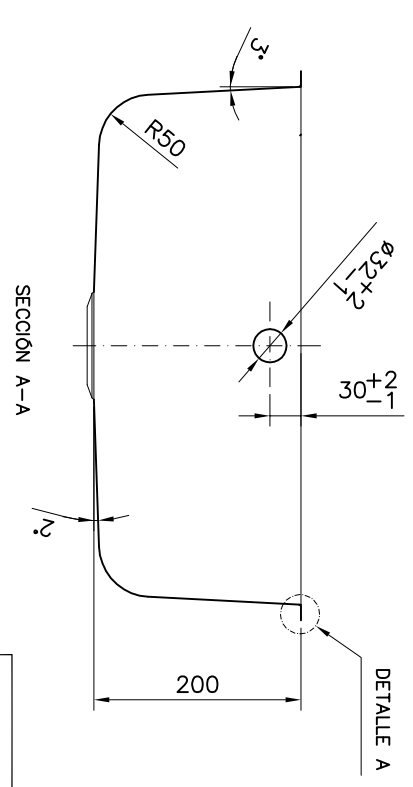

SECCIÓN A-A

DETALLE A

REV	DESCRIPCIÓN DEL CAMBIO / DESCRIPTION OF CHANGE	LOC.	POR / BY	FECHA / DATE

THIS DRAWING IS THE PROPERTY OF TEKA INDUSTRIAL, S.A. IT CONTAINS CONFIDENTIAL INFORMATION BELONGING TO AND/OR ENTRUSTED TO TEKA. IT IS DISCLOSED IN CONFIDENCE AND SHALL NOT BE HELD, REPRODUCED OR USED EXCEPT IN A MANNER AND FOR A PURPOSE EXPRESSLY PERMITTED BY TEKA IN WRITING.
 TOLERANCIAS GENERALES / TOLERANCE UNLESS OTHERWISE SPECIFIED: ISO 2768 -mK

MATERIAL: Acero inox 1.4301, 2B, EPR, 141 840x890x1 mm. Film SPV 3067 M 878 mm

UNITS: mm	FIRST ANGLE PROJECTION	Fecha de edición / Creation date	Creado por / Created by
ESCALA / SCALE 1:5		02.03.15	C.R.G.
DO NOT SCALE		Tipo de Documento/Document Type: Reglamento por / Regulated by	M.A.C.

INTERPRETATION PER ISO 1101
 = CARACTERÍSTICA SIGNIFICATIVA / CONTROL

FREGADERO BE 50.40.20 PLUS



Teka Industrial, S.A.
 Santander, SPAIN

DRAWING SIZE	HQA / SHEET	PLANO Nº / DRAWING NUMBER	SUBSTITUTE A / REPLACE TO
A3	1 OF 1	AA 15486	AY 15486

CÓDIGO / PART NO.

